

An Optimum Hardware Detector for Constant Envelope Quadrature-Quadrature Phase-Shift Keying (CEQ²PSK)

Kenneth V. Cartwright
School of Sciences and Technology
College of The Bahamas
P.O. Box N4912
Nassau, N.P., Bahamas
kvc@batelnet.bs

Edit J. Kaminsky
Department of Electrical Engineering
EN 852 Lakefront Campus
University of New Orleans
New Orleans, LA 70148, U.S.A.
ejbourge@uno.edu

Abstract—A hardware detector for constant envelope quadrature-quadrature phase-shift keying (CEQ²PSK) is proposed. It uses appropriate hard decisions; yet, it achieves optimum probability of bit error performance, unlike the suboptimum detector of Saha and Birdsall. This optimum performance is verified through Monte Carlo computer simulations. Additionally, a more correct expression is given for the probability of bit error performance for CEQ²PSK, which gives the gain over non-constant Q²PSK as 1.44 dB, rather than the previously published value of 1.76 dB.

Index Terms—Quadrature-quadrature phase shift keying, constant envelope, optimum detector, four-dimensional modulation.

I. INTRODUCTION

QUADRATURE-quadrature phase-shift keying (Q²PSK) and constant envelope Q²PSK (CEQ²PSK) were introduced by Saha and Birdsall in [1]. A simple block encoder of rate 3/4 at the input of a Q²PSK modulator is used to produce a set of 8 biorthogonal codewords given by the constant envelope signals. Constant amplitude is desirable in nonlinear channels; it avoids the variations in phase produced by changing amplitude, which in turn has detrimental effects in the bit error rate for coherent demodulation. The constant envelope feature in CEQ²PSK is achieved at the expense of bandwidth efficiency because the information transmission rate is 3/(2T) for CEQ²PSK while it is 2/T for non-constant Q²PSK.

It is shown in [1] that CEQ²PSK can provide a 50 percent increase in bandwidth efficiency over minimum shift keying (MSK) at the cost of 0.7 dB increase in the average bit energy, assuming bandlimiting has taken place at the transmitter and receiver, through the use of sixth-order Butterworth filters with half power bandwidth equal to 1.2/T, where the bit rate is 2/T. The information bit transmission rate is 3/(2T). To achieve this performance an optimum receiver is needed; to date, however, no simple optimum hardware receiver has been proposed for this modulation scheme. Indeed, Saha and Birdsall recognized that a nonoptimum receiver based on hard decisions might be of interest for its simplicity. The simple hardware receiver provided by Saha and Birdsall performed

substantially worse than the optimum, as seen in Fig. 11 of [1].

The greater flexibility for spreading afforded by higher dimensional modulation schemes such as Q²PSK and CEQ²PSK was exploited in [2] for direct-sequence spread spectrum systems (DSSS).

A hybrid block-convolutional coding scheme for CEQ²PSK is shown in [3] to improve performance by 1.5 dB at bit error rate (BER) of 10⁻⁴ both in additive white Gaussian noise (AWGN) and Rician fading channels with moderate fading. More substantial improvements are obtained with more severe fading. Saha and Birdsall's sub-optimum decoder is used there also.

Digital implementations of CEQ²PSK transmitter and receiver are discussed in [4], while carrier phase and clock recovery in CEQ²PSK using a data-aided algorithm are investigated in [5]. The receiver in [4] is an implementation of Saha and Birdsall's non-optimum receiver and the practical curve in Fig. 4 of [4] is close to the non-optimum detection curve in Fig. 11 of Saha and Birdsall's original paper [1]. That receiver, then, does not optimally detect CEQ²PSK, whereas ours does. Our method requires five hard-limiters and the decision vector is just the correct combination of four of these hard-limited outputs.

An optimum receiver for minimum bandwidth Q²PSK was proposed in [6]; it employs a matched filter receiver with hard-limiter detectors that uses two hard-limiters to form a decision variable for one of the outputs. The method in [6] still requires a maximum likelihood (ML) Viterbi decoder to form the decisions for the other three quantities to be decoded.

We will show in this paper that, fortunately, a much simpler optimum receiver for CEQ²PSK can be implemented in hardware using hard decisions.

A final contribution of this paper is to give a more accurate gain of CEQ²PSK over Q²PSK. Saha and Birdsall claim in [1] that CEQ²PSK provides 1.76 dB of gain over non-constant envelope Q²PSK. However, it is shown here that this figure is too optimistic, because it ignores the effects of the error coefficient, which will reduce this gain by about 0.32 dB to around 1.44 dB.

The remainder of this paper is organized as follows: In Section II we briefly review CEQ²PSK. Our new optimum hardware detector for CEQ²PSK is detailed in Section III. The performance of the detector is evaluated in Section IV. Concluding remarks and references follow.

II. BRIEF REVIEW OF CEQ²PSK

A non-constant envelope Q²PSK signal can be written as

$$\begin{aligned}
 s(t) = & a_1(t) \cos\left(\frac{\pi t}{2T}\right) \cos(2\pi f_c t) + \\
 & + a_2(t) \sin\left(\frac{\pi t}{2T}\right) \cos(2\pi f_c t) + \\
 & + a_3(t) \cos\left(\frac{\pi t}{2T}\right) \sin(2\pi f_c t) + \\
 & + a_4(t) \sin\left(\frac{\pi t}{2T}\right) \sin(2\pi f_c t),
 \end{aligned} \tag{1}$$

where $f_c = n/4T$ is the carrier frequency, with n any integer greater than or equal to two, $\{a_i(t), i = 1, 2, 3, 4\}$ are four data streams that have been demultiplexed from a binary data source of bit rate $2/T$. Each data pulse in the demultiplexed streams is a rectangular shaped pulse with strengths ± 1 and duration $2T$. With the given restriction on carrier frequency, (1) can be written as a vector as

$$s(t) = [a_1(t), a_2(t), a_3(t), a_4(t)]. \tag{2}$$

Furthermore, (1) can be written as

$$s(t) = A(t) \cos(2\pi f_c t + \theta(t)), \tag{3}$$

where $\theta(t)$ is the carrier phase and $A(t)$ is the carrier amplitude given by

$$A(t) = \left(2 + (a_1 a_2 + a_3 a_4) \sin \frac{\pi t}{T} \right)^{1/2}. \tag{4}$$

Clearly, for the envelope to be a constant and produce CEQ²PSK we must have $a_1 a_2 + a_3 a_4 = 0$. Therefore, the eight possible transmitted four-dimensional (4D) signals for CEQ²PSK are $S_1 = [a, a, b, -b]$ or $S_2 = [a, -a, b, b]$, where a, b are either +1 or -1.

The received CEQ²PSK signal is assumed to have been corrupted by additive white Gaussian noise (AWGN) with two-sided power spectral density $N_0/2$ in each of the four dimensions. It is also assumed that there is no bandlimitation in the channel, other than that provided by the integrate-and-dump filters that are part of the demodulator. Hence, the received demodulated signals, which are sampled every $2T$ seconds, can be represented as:

$$\begin{aligned}
 a_{1r}(2mT) &= a_1(2mT) + n_1(2mT) \\
 a_{2r}(2mT) &= a_2(2mT) + n_2(2mT) \\
 a_{3r}(2mT) &= a_3(2mT) + n_3(2mT) \\
 a_{4r}(2mT) &= a_4(2mT) + n_4(2mT),
 \end{aligned} \tag{5}$$

where m is an integer, $n_i(2mT)$, $i=1, 2, 3, 4$, is a zero-mean normal random variable with variance $\sigma^2 = N_0/2T_s$, with T_s the signal length, which is equal to $2T$.

Decisions have to be made from the demodulated signals of (5), to produce the estimates $\hat{a}_1, \hat{a}_2, \hat{a}_3, \hat{a}_4$ of the transmitted data bits of (2). This is the job of the detector.

III. THE PROPOSED CEQ²PSK HARDWARE DETECTOR

It is well known that the probability of bit error depends critically on the ratio d_{free}^2 / σ^2 , where d_{free}^2 is the minimum squared Euclidean distance between constellation points, i.e. codewords. Indeed, $d_{free}^2 = 8$ for the CEQ²PSK codewords listed in the previous section.

The key to developing an optimum hardware-based detector is to discover functions of the received demodulated signals that can be hardlimited, without compromising this critical ratio. The method to do this is described in what follows. The result of the development is shown in Fig. 1, where our complete CEQ²PSK receiver, including demodulator and detector, is shown.

First, assume that a member of S_1 was transmitted. Then, as is shown below, it is easy to detect which member of S_1 was transmitted, by hardlimiting. This produces the estimate $\hat{S}_1 = [\hat{a}, \hat{a}, \hat{b}, -\hat{b}]$, one of four possible symbols.

Second, assume that a member of S_2 was transmitted. Again, hardlimiting is used to determine which member of S_2 was transmitted, and produce the estimate $\hat{S}_2 = [\hat{a}, -\hat{a}, \hat{b}, \hat{b}]$, one of four possible symbols.

Now, thirdly, we must decide whether a member of S_1 or S_2 was transmitted. Let $d = 1$ if the transmitted signal belongs to S_1 , and $d = 0$ if it belongs to S_2 . It is also straightforward to determine \hat{d} , the estimate for d , by hardlimiting. Indeed, this is the function of the F(·) block of Fig. 1 which requires four absolute value circuits and one hardlimiter, as we will prove shortly.

Fourthly, based upon the decision of the previous step, the detector must send the correct of the two detected symbols to the output. This task is performed by the four-pole double-throw electronic switch in Fig.1. Mathematically, the detected CEQ²PSK symbol can be described by

$$\hat{S} = d\hat{S}_1 + (1 - \hat{d})\hat{S}_2. \tag{6}$$

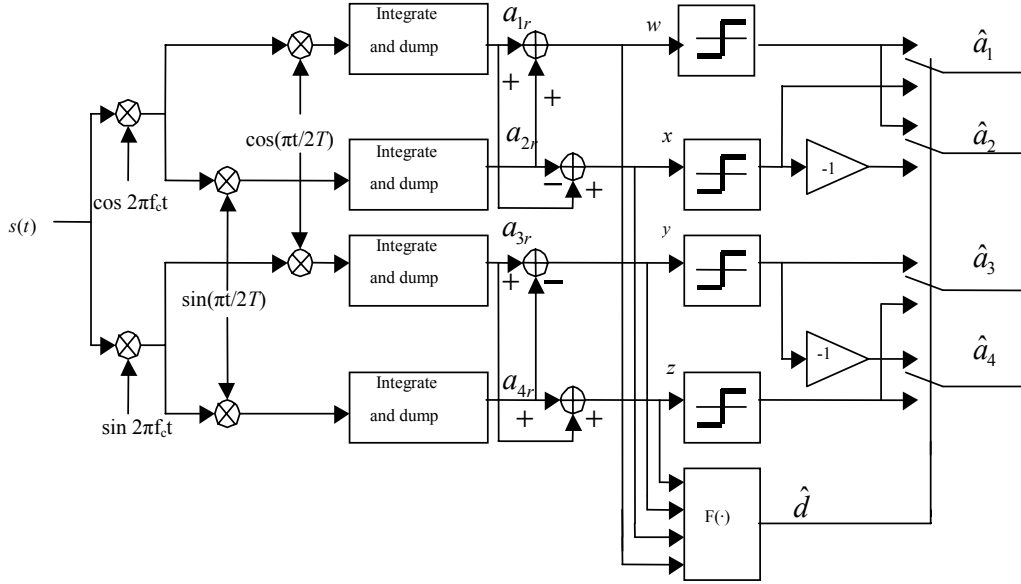

Fig.1. Block diagram of the proposed optimum CEQ²PSK demodulator and detector.

As mentioned earlier, it is necessary to detect which member of S_1 has been transmitted. To do this, we let $w = a_{1r} + a_{2r}$; for all members of S_1 this yields $w = 2a + n_1 + n_2$. Notice that w can be considered a bipolar binary signal which can be detected by symmetric hard-limiting. Furthermore, for this binary signal, $d_{free}^2 = 16$ and the variance of $n_1 + n_2$ is $2\sigma^2$. Hence, the critical ratio remains unchanged at $8/\sigma^2$. Similarly, we let $y = a_{3r} - a_{4r}$. Then, $y = 2b + n_3 - n_4$. Again, y can be considered a bipolar binary signal easily detected by hardlimiting, with no change in the critical ratio. Therefore, the detected 4D codeword for S_1 can be written as $\hat{S}_1 = [\text{sgn } w, \text{sgn } w, \text{sgn } y, -\text{sgn } y]$, where $\text{sgn}(v) = 1$ for $v \geq 0$, and $\text{sgn}(v) = -1$ for $v < 0$.

In like fashion, it is easy to detect which member of S_2 was transmitted. Indeed, $\hat{S}_2 = [\text{sgn } x, -\text{sgn } x, \text{sgn } z, \text{sgn } z]$, where $x = a_{1r} - a_{2r}$ and $z = a_{3r} + a_{4r}$.

Also, as mentioned earlier, there is a need to determine \hat{d} . The method to do this will now be described. Notice that if a member of S_1 is transmitted and noise is ignored, the four possible values for $u = [w, x, y, z]$ are $[2 \ 0 \ 2 \ 0]$, $[2 \ 0 \ -2 \ 0]$, $[-2 \ 0 \ 2 \ 0]$, and $[-2 \ 0 \ -2 \ 0]$, and therefore we have $|u| = [|w|, |x|, |y|, |z|] = [2 \ 0 \ 2 \ 0]$. On the other hand, if a member of S_2 is transmitted, $|u| = [0 \ 2 \ 0 \ 2]$.

Luckily, the binary vector $|u|$ does not compromise the critical ratio. Hence, if $(|w| - 2)^2 + |x|^2 + (|y| - 2)^2 + |z|^2 <$

$|w|^2 + (|x| - 2)^2 + |y|^2 + (|z| - 2)^2$ then $\hat{d} = 1$, and it is determined that S_1 was transmitted. However, if the inequality is not satisfied, $\hat{d} = 0$, and it is determined that S_2 was transmitted. Furthermore, the above inequality simplifies to $|w| + |y| > |x| + |z|$. Hence,

$$\hat{d} = \frac{1}{2} [\text{sgn}(|w| + |y| - |x| - |z|) + 1]. \quad (7)$$

The function block $F(\cdot)$ in Fig. 1 computes the result of (7) and therefore determines \hat{d} , the estimate of the unipolar binary variable d , which in turn activates the switch to pass the correct symbol (from \hat{S}_1 if $\hat{d} = 1$, from \hat{S}_2 if $\hat{d} = 0$) to the output.

Superficially, Fig. 3 of [4] resembles our receiver. The summers there, however, are performing a different function than our summers: theirs are simply forming the decision variables with two of them just clipping, which means that they are not detected optimally, as the squared distance is only 4 whereas the squared distance between nearest CEQ²PSK symbols is actually 8. On the other hand, our summers are ensuring that the critical ratio is maintained.

Also, the decoders in [1, 3, 4] assume that correct decisions about a_1 and a_3 have been made and use these along with the estimates a_{2r} and a_{4r} to make decisions about a_2 .

IV. PERFORMANCE VERIFICATION OF OUR DETECTOR

In order to verify the derivations in the previous section, Monte Carlo simulations were performed. For each signal-to-noise ratio (SNR), i.e., E_b/N_o , the simulation ran until twenty symbol errors were committed. According to [7], this allows

the probability of bit error to be estimated with a standard deviation equal to less than half of the true probability of bit error value.

The theoretical probability of symbol error is given by

$$P_s(E) = K \operatorname{erfc} \sqrt{\frac{3E_b}{2N_o}}, \quad (8)$$

where $\operatorname{erfc}(\cdot)$ is the complementary error function, and K is the error coefficient normalized to $2D$, equal to $N/2$, where N is the average number of neighbors from a given symbol at a squared distance of eight. For CEQ²PSK, it is easily verified that N is 6 and therefore K is 3.

To find the probability of bit error, $P_b(E)$, it is necessary to know how the three information bits are mapped to the eight 4D symbols. Ideally, a Gray code would be used to do this, so that one symbol error causes only one bit error. However, it is not possible to do this (because there are six neighbors and the Gray code only allows three). The best that can be achieved is an average of 1.5 bit errors for each symbol error.

For our simulations, the three information bits were assigned to a_1 , a_2 , and a_3 ; a_4 was then derived to satisfy the constant amplitude condition $a_1 a_2 + a_3 a_4 = 0$. With this mapping, there are an average of one and a half bit errors for every symbol (3 information bits) error. Hence,

$$P_b(E) = P_s(E) / 2 = 1.5 \operatorname{erfc} \sqrt{\frac{3E_b}{2N_o}}. \quad (9)$$

This means that the error coefficient is 1.5 and not 0.5 as Saha and Birdsall assumed in [1]. Hence, the SNR suffers a loss of about $0.2 \log(3)/\log(2)$ or 0.32 dB as given by Forney [8]. The gain, then, of CEQ²PSK over non-bandlimited non-constant Q²PSK is not 1.76 dB, but more like 1.44 dB. This was corroborated during our simulations also.

The experimental probability of bit error is plotted in Fig. 2 (shown as asterisks, along with the theoretical CEQ²PSK curve from (9) and the curve for non-constant Q²PSK. As can be seen, there is very good agreement between the theoretical value and the Monte Carlo simulation experimental results. We also see in Fig. 2 that at BER of 10^{-6} the gain of CEQ²PSK over Q²PSK is about 1.4 dB.

Additionally, the optimum detector was simulated simultaneously with our new detector. No bit errors were discovered for our proposed detector that were not also found for the optimum detector. Thus, the proposed hardware detector does indeed give optimum performance, as claimed.

V. CONCLUSIONS

We have presented an optimum hardware detector for constant envelope quadrature-quadrature phase shift keying (CEQ²PSK). Five hardlimiters, four adders, four absolute

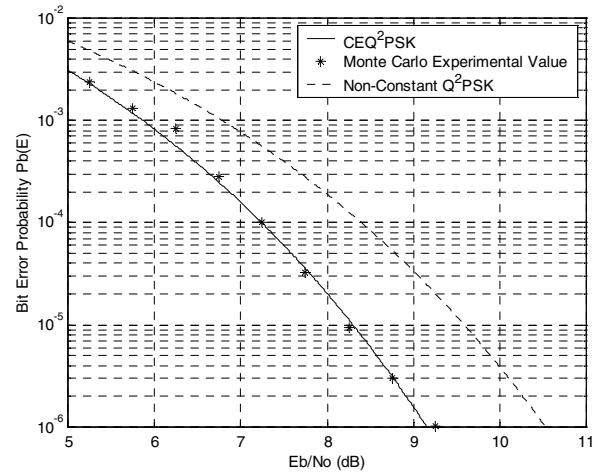

Fig. 2. Bit error probabilities as a function of E_b/N_o for CEQ²PSK and Q²PSK.

value circuits, two inverters, and a four-pole double-throw switch are needed to implement the decoder. Monte Carlo simulations show that the performance indeed matches the theoretical value for bit error probabilities. The gain of CEQ²PSK over non-constant Q²PSK was shown to be around 1.44 dB.

REFERENCES

- [1] D. Saha and T. G. Birdsall, "Quadrature-quadrature phase-shift keying," *IEEE Trans. Commun.*, vol. 37, pp. 437–448, May 1989.
- [2] J. E. Cilliers, L. P. Linde, and D. J. Van Wyck, "A synchronous Q²PSK DS-CDMA system: System conceptualisation, implementation and performance analysis," in *Proc. 5th Internat. symposium on spread spectrum tech. and appl.*, vol. 1, pp. 4–8, 2–4 Sept., 1998.
- [3] D. J. van Wyk and L. P. Linde, "Hybrid block-convolutional rate-1/2 coding strategy for constant envelope (CE) Q²PSK," *Electronics Letters*, vol. 32, no. 24, 21 Nov. 1996.
- [4] V. Acha and R. A. Carrasco, "A new digital implementation of quadrature-quadrature phase shift keying," in *3rd IEE Internat. Conf. Telecommun.*, pp. 29–34, 17–20 March 1991.
- [5] V. Acha and R. A. Carrasco, "New data-aided carrier and clock recovery algorithms for Quadrature-Quadrature Phase Shift Keying (Q²PSK)," in *IEE Colloquium on Adv. Modul. and Coding Tech. for Satellite Commun.*, pp. 2/1–2/5, 27 Jan. 1992.
- [6] D. J. van Wyk and L. P. Linde, "Rate-1/2 trellis coding for Q²PSK operating on the Rician fading channel," *The Transactions of the SAIEE*, pp. 33–39, Mar. 1998.
- [7] K. S. Shanmugam and P. Balaban, "A modified Monte-Carlo simulation technique for the evaluation of error rate in digital communication systems," *IEEE Trans. Commun.*, vol. 28, pp. 1916–1924, Nov. 1980.
- [8] G. D. Forney, Jr., "Coset codes-Part I: Introduction and geometrical classification," *IEEE Trans. Inform. Theory*, vol. 34, pp. 1123–1151, Sept. 1988.